

# Kidde Fire Systems

## Marine Series Component Description



Effective: April 2023  
K-85-9170 Rev AA

### 3-Way Cross-Over Valve, 3 or 4 in.

#### FEATURES

- *Low Loss Three-Port Design for 'Cross-Over' Functionality*
- *For Approvals, see the "Compatibility" table on page 4.*
- *Manual Operation with 8-inch Wheeled Gear Operator*
- *RoHS Compliant*
- *3 and 4 inch Connection Sizes Available for Use with Grooved Couplings for Ease of Installation*
- *High Quality Materials for Excellent Corrosion Resistance*
- *Pre-Drilled for Optional Limit Switch*

P/N 90-30000X-000

#### DESCRIPTION

The Kidde Fire Systems 3-Way Cross-Over Valve is designed for use in systems configured to comply with International Maritime Organization (IMO) High Speed Craft (HSC) Code requirements for agent distribution where a vessel is fitted with individual systems protecting individual spaces (i.e., a twin hull catamaran with port and starboard systems protecting port and starboard engine rooms). If a reserve (or second) shot of agent is required, two crossover valves can be installed in the pipe work of two systems allowing agent from one system to be released into the other.

The valve has a rotor valve design with a plated steel body and rotor with stainless steel fittings and mounting hardware. A gear operator unit is installed via a coupling and is secured via a mounting kit to studs in the valve body. Pipe connections are made via 3 or 4 in. grooved fittings. The position display disc, located on the upper face of the gear operator, indicates the orientation of the internal porting. For ease of operation, an 8 in. hand-wheel is installed to facilitate rapid position changes.

**Note:** The design of the valve and actuator mechanism, in conjunction with the unique arrangement of the two valves for this application, ensure that it is not possible to release agent from one system in both spaces simultaneously nor agent from both systems in to one space. In fact, this arrangement is safer than conventional distribution systems employed in CO<sub>2</sub> systems in this respect.

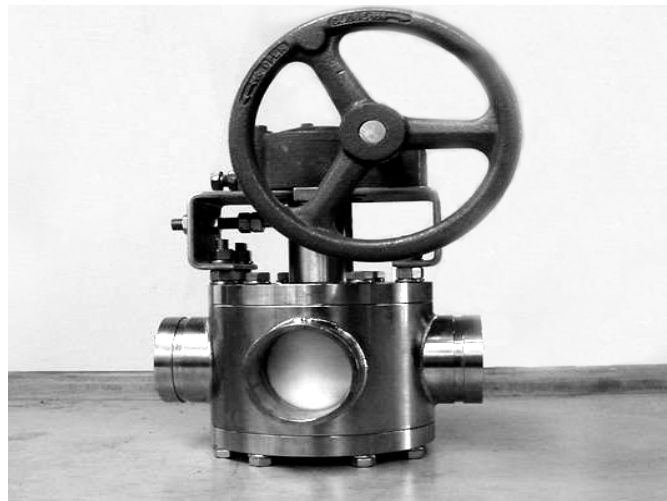

#### OPERATION

The default arrangement for a typical installation of two valves is straight-through (see Figure 1). In this position, the agent stored in each container is available for discharge into the matched distribution pipe work and protected space.

If a fire occurs in one of the protected spaces, and a second release of agent is required (e.g., a second fire occurs or re-ignition occurs following ventilation of the space), the valves can then be operated to reroute the remaining agent.

The mode of operation for the second release would be to first isolate remote release controls (if installed), then locate the valve controls and operate both valves to achieve the required orientation. See Figure 1 for more details. When the valves are orientated correctly, the agent can be released by manually operating the agent cylinder control.

#### INSTALLATION

Valves must be installed so that the hand-wheels are accessible and that the position indicators are clearly visible. Grooved pipe couplings should be used to connect to the system piping, with a minimum of 500 PSI (35 bar) pressure rating. Pipe supports should be located as close to valve as possible to support the weight of the valves.

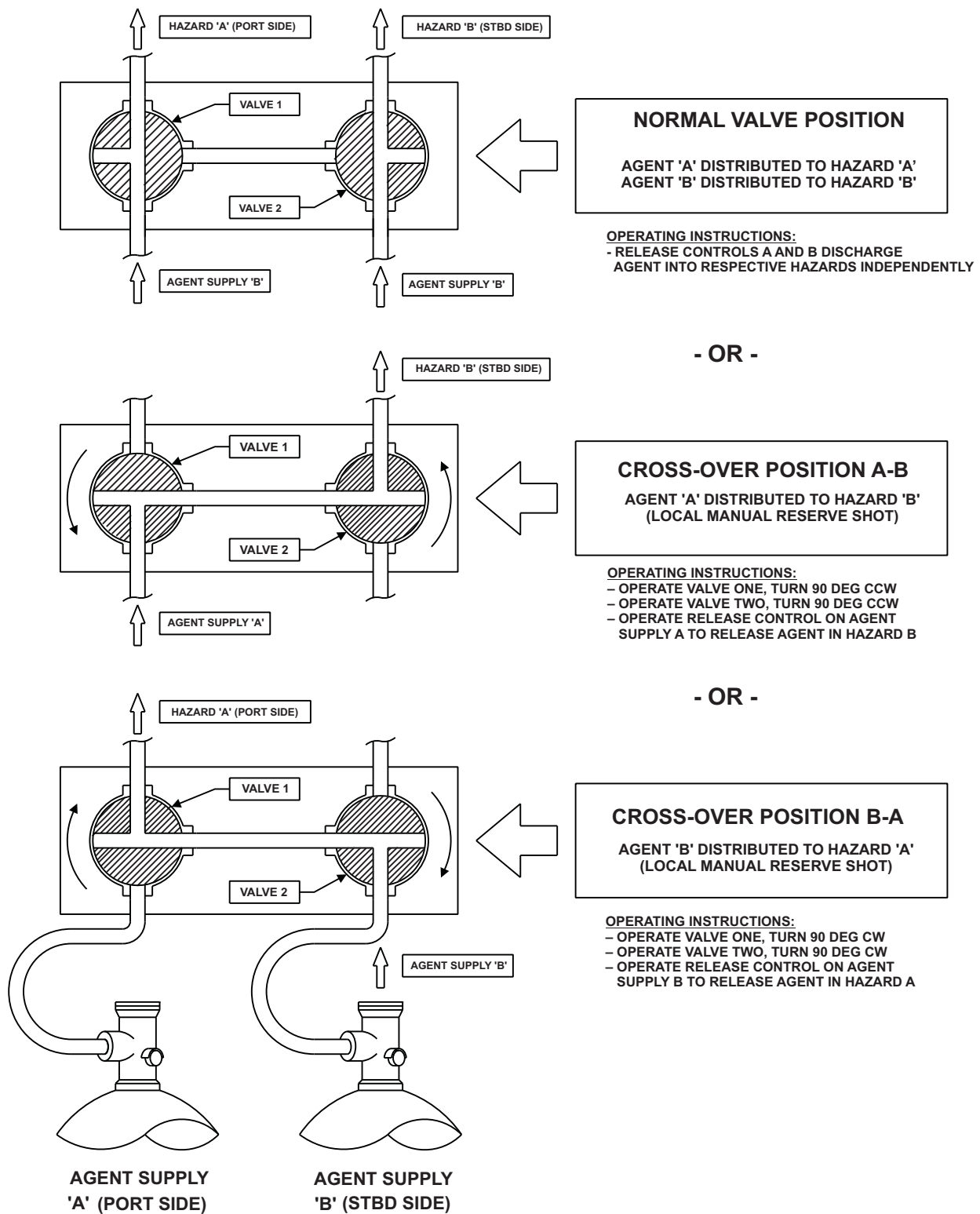

Figure 1. Operation Schematic

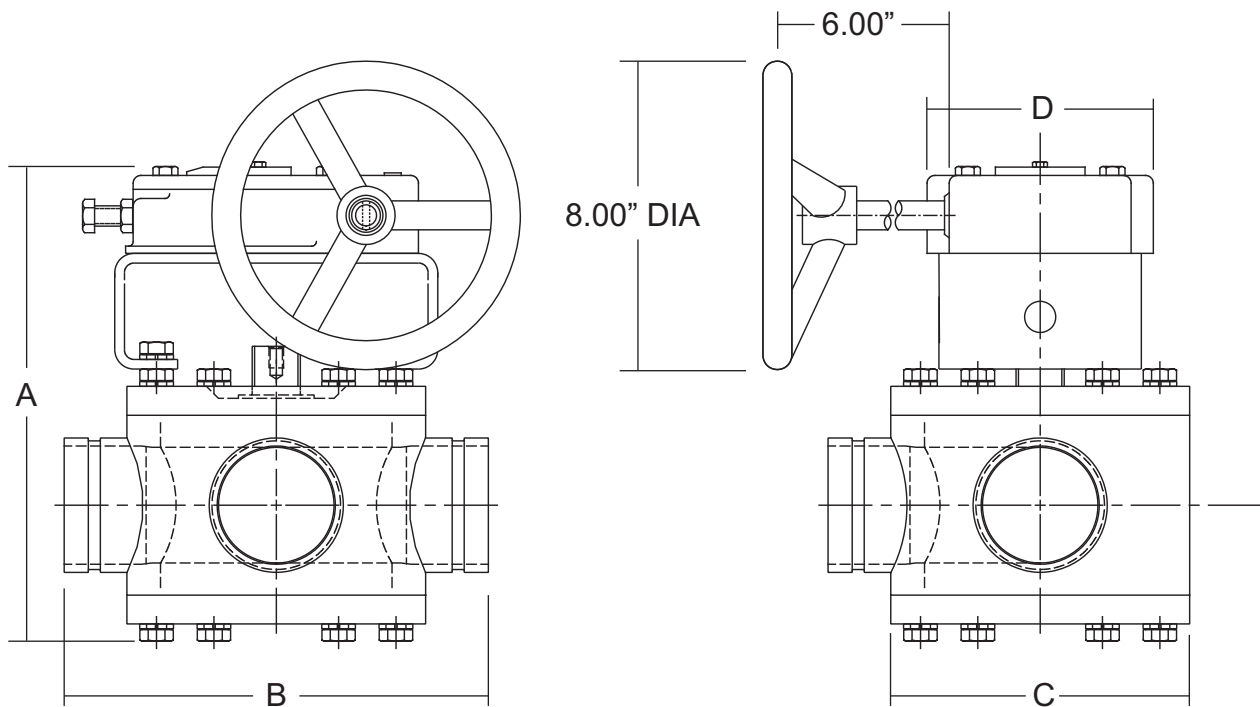

Figure 2. Cross-over Valve

Table 1: Cross-over Valve Dimensions

Part Number	Valve Size	A	B	C	D
90-300007-001	3 in.	12.56 in.	11.00 in.	7.75 in.	5.00 in.
90-300008-001	4 in.	14.62 in.	13.38 in.	10.00 in.	6.50 in.

**SPECIFICATIONS**

<b>Unit Weight:</b>	74 lb. (33.5 kg)
<b>Materials:</b>	Valve rotor and body: Steel electroless nickel plated
	Mounting Kit and hardware: Stainless steel
	Gear operator: Steel
<b>Operating Temperature Range</b>	30°F to 130°F (0°C to 54°C)

**ORDERING INFORMATION**

Part Number	Description
90-300007-001	3-Way Cross-Over, 3 inch
90-300008-001	3-Way Cross-Over, 4 inch

## COMPATIBILITY

Series	DIOM P/N	Approvals
Kidde Fire Systems ECS-500™ Marine System	06-237589-001	UL, ULC, USCG
Kidde Fire Systems ADS™ Marine for use with Fluoroketone Fire Suppression Agents	06-237257-001	UL, ULC, USCG
Kidde Fire Systems ADS™ Marine with HFC-227ea Agent	06-236595-001	UL, ULC, USCG
Kidde Fire Systems ECS™ 360 Marine for use with Fluoroketone Fire Suppression Agents	06-236559-001	UL, ULC, USCG
Kidde Fire Systems ECS™ 360 Marine with HFC-227ea Agent	06-236225-001	UL, USCG

### EXPORT INFORMATION (USA)

Jurisdiction: EAR  
Classification: EAR99

This document contains technical data subject to the EAR.

All trademarks are the property of their respective owners.

This literature is provided for informational purposes only. KIDDE-FENWAL, INC. believes this data to be accurate, but it is published and presented without any guarantee or warranty whatsoever. KIDDE-FENWAL, INC. assumes no responsibility for the product's suitability for a particular application. The fire suppression system design, installation, maintenance, service and troubleshooting must be performed by trained, authorized Kidde Fire Systems distributors for the product to work correctly. If you need more information on this product, or if you have a particular problem or question, contact: KIDDE-FENWAL, INC., Ashland, MA 01721 USA, Telephone: (508) 881-2000.